

Electromagnetic Compression as Preforming Operation for Tubular Hydroforming Parts *

V. Psyk, C. Beerwald, W. Homberg, M. Kleiner

Chair of Forming Technology, University of Dortmund, Germany

Abstract

With the aim to extent the forming limits of tube hydroforming a concept of using a previous electromagnetic compression operation will be introduced. One important limit for the possibilities of tube hydroforming is set by the initial circumference and the maximum tangential strain of the used material, whereby the initial circumference is typically determined by the smallest local circumference of the workpiece. The application of an appropriate contoured preform makes it possible to use tubes with a larger initial circumference.

In the paper the investigation of the suitability of electromagnetic tube compression for the production of such a preform will be presented. The valuation is based on geometric criteria and material properties of the resulting preform which are strongly influenced by the process parameters. The discussed aspects are the roundness of the preform and the strain hardening of the material.

Keywords:

Electromagnetic forming, Tube compression, Hydroforming, Process combination

*The present study has been performed by the authors within the European project "Electromagnetic forming of tube and sheet metal for automotive parts – EMF – G3RD-CT-2002-00798". The conclusions drawn and the views put forward here do only reflect the opinions of the authors and not necessarily those of the rest of the project consortium. The project has been funded by the European Commission and the consortium has the following partners: Volvo Cars Body Components, Centro Recherche Fiat SCpA, DaimlerChrysler AG, PSA Peugeot- Citroën Automobiles, Alcan Technology & Management Ltd, Beijing Research Institute of Mechanical and Electrical Technology, ESI SA, University of Dortmund and University of Trento.

1 Introduction

The production of complex components from tubular semi-finished parts is often realised by hydroforming. Especially for the forming of lightweight construction components for the automotive industry the hydroforming process represents a new technique and offers a new production potential. [1, 2, 3, 4]

The achievable strain of hydroformed tubes is limited by the stress strain behaviour of the workpiece material as well as by the initial circumference of the tube. The smallest local circumference of the finished workpiece geometry typically determines the maximum possible initial tube circumference. This forming limit can be extended by applying an appropriate contoured preform which makes it possible to use tubes with a larger initial circumference for the hydroforming process. These tubes are locally compressed during the preforming operation.

Since the automotive industry uses more and more hydroforming parts from aluminium alloys the electromagnetic forming process (EMF) seems to open up new possibilities for such preforming operations. For the EM- compression process the tube is arranged within a compression coil, and a pulsed magnetic field in the gap between tool coil and tube generates a strong pressure pulse in radial direction. This short pressure pulse causes a symmetric reduction of the tube diameter with typical strain rates of about 10^4 s^{-1} . In comparison to conventional quasistatic forming processes the EMF process offers several advantages, as for example

- **the possibility to compress rotationally symmetric geometries without a form defining tool (mandrel):**
Due to the high forming velocities, localising effects are reduced and the compression process can be performed as a free forming operation. For example, a compression operation would be difficult by means of hydroforming and it is not practicable without a mandrel.
- **the possibility to perform a compression process in a process chain after a bending operation:**
In contrast to incremental forming processes, like e.g. spinning, the EMF- compression is not limited to straight profiles, but it can be performed close to corners and radii.
- **the possibility to form geometries which are not rotationally symmetric:**
If the EMF- process is performed with a form defining tool it is possible to use mandrels with cross sections which are not round. The potential geometries are limited by the possibilities to remove the mandrel from the tube. Therefore, it is not possible to realise indentations using this forming strategy.

In the following paper the investigation of the suitability of electromagnetic tube compression as a preforming operation in combination with the hydroforming process will be presented. The valuation is based on geometric criteria and material properties of the resulting preform which are strongly influenced by the process parameters. The most important aspects for the investigation are wrinkling effects, respectively the roundness of the preform, and the strain hardening of the material. In the present article some basic correlations concerning the effects of the electromagnetic forming on the workpiece will be presented and results of the free compression process as the most simple setup will be shown for one selected material (AA 5754).

2 Determination of Significant Process Parameters

An important precondition for the valuation and optimisation of the electromagnetic pre-forming operation is the knowledge of significant process parameters and their influence on the forming process as well as on the forming result.

The effective load acting on the workpiece is one important aspect affecting the process. It is influenced by properties of the tool coil, the forming machine, and the charging energy of the capacitor battery. For the definition and quantification of the effective load, the pressure distribution and the pressure course can be used. The pressure course is characterised by its maximum and duration, both influencing the achievable tangential strain in a free forming operation, as well as the pressure rise time which significantly influences the forming velocity.

Due to this perception, the description of the acting load becomes independent of the EMF- equipment. For the determination of the magnetic pressure p the measured coil current serves as an input. On this basis the course and the distribution of the magnetic field and the magnetic pressure can be calculated [5,6].

In addition to the load, the initial condition of the workpiece also has a great influence on the deformation process and the forming result. It can be described by geometric attributes including diameter, roundness, wall thickness, and its distribution as well as by material properties like strength, hardness, and maximum strain determined by the quasistatic tensile test and the quasistatic burst test.

The investigations presented in the following article have been performed using tubes made of AA 5754 with a nominal diameter of 40 mm and a nominal wall thickness of 2 mm. To classify the initial condition of the tube material, exact values of the inner and outer roundness as well as the wall thickness distribution along the circumference are shown in Figure 1.

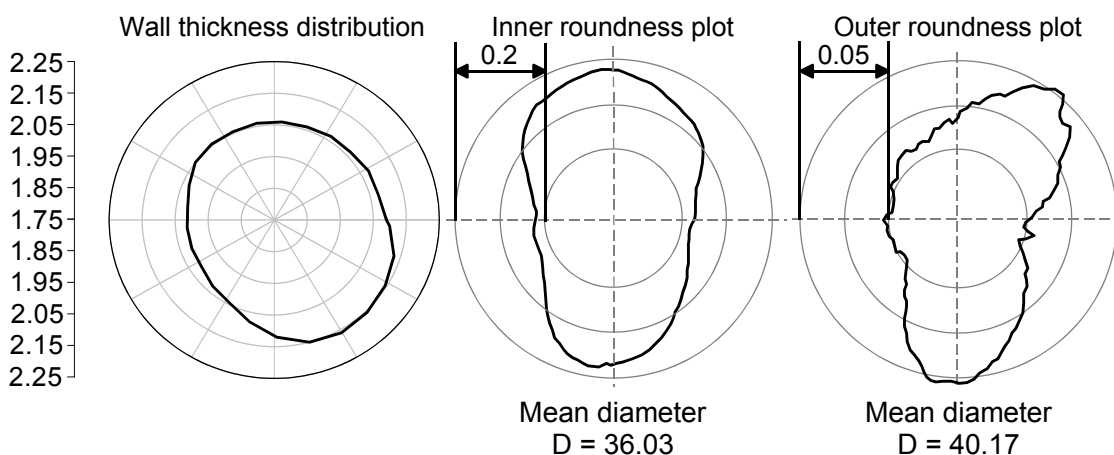

Figure 1: Roundness and wall thickness distribution of the investigated material

According to the requirements for extrusion profiles defined in DIN EN 12020-2, the tolerance for the diameter is ± 0.3 mm and the tolerance for the wall thickness is ± 0.25 mm. As it can be seen in Figure 1 the used material meets these demands. Furthermore, the investigated material has been produced without any extrusion seams, so that a good homogeneity of the material along the circumference is granted.

Additional material characteristics have been determined by means of Vickers hardness tests, tensile tests, and hydraulic burst tests. The determined data is summarised in Table 1.

Tensile strength R_m	approx. 250 N/mm ²
Yield strength $R_{p0.2}$	approx. 125 N/mm ²
Maximum axial strain (quasistatic tensile test) $A_{0, axial}$	approx. 23%
Maximum tangential strain (quasistatic burst test) $A_{0, tangential}$	approx. 8%
Vickers hardness HV	approx. 81 HV5

Table 1: Material characteristics of the investigated material

The effective load and the material properties of the workpiece represent the input parameters of the forming process, causing the deformation behaviour of the workpiece. This behaviour includes the radial deformation, the forming velocity, and the final geometry, characterised by roundness and contour, as well as the increase of strength and hardness of the material.

The online measurement of the radial deformation is performed by means of an optic method. The shadowing of a linear laser beam, which shines in axial direction through the workpiece, is measured by a Position Sensitive Device (PSD). The voltage signal of the PSD is proportional to the radial deformation of the tube's smallest cross section. On this basis the tangential strain and the strain rate can be calculated[5, 6].

3 Influence of the Tangential Strain

3.1 Correlation between Tangential Strain and Roundness

As already mentioned, the pressure course can be characterised by the pressure maximum and the pressure rise time. If the parameters of the forming machine, the tool coil, and the workpiece are equal an increase of the charging energy will lead to an increase of the pressure maximum, while the pressure rise time remains approximately the same.

The resulting geometry of tubular specimen compressed in free forming operations with different maximum pressures has been measured with a coordinate measurement system and exemplary results are presented in Figure 2.

As expected, an increase of the pressure maximum leads to a higher deformation of the workpiece. Furthermore, the increasing tangential strain is correlated to a worsening of roundness respectively to an increasing wrinkling effect. This wrinkling effect seems to be connected to the distribution of the tube's wall thickness. The reason might be that the stiffness of the tube, which is characterised by the ratio of wall thickness and radius, decreases with a decreasing wall thickness, and that a smaller stiffness is more susceptible to wrinkling. Another aspect influencing the roundness is the homogeneity of the material. As already mentioned, the investigated material is of good homogeneity. In other cases it can be expected that inhomogeneities, like e.g. extrusion seams, cause earlier and more extreme wrinkling.

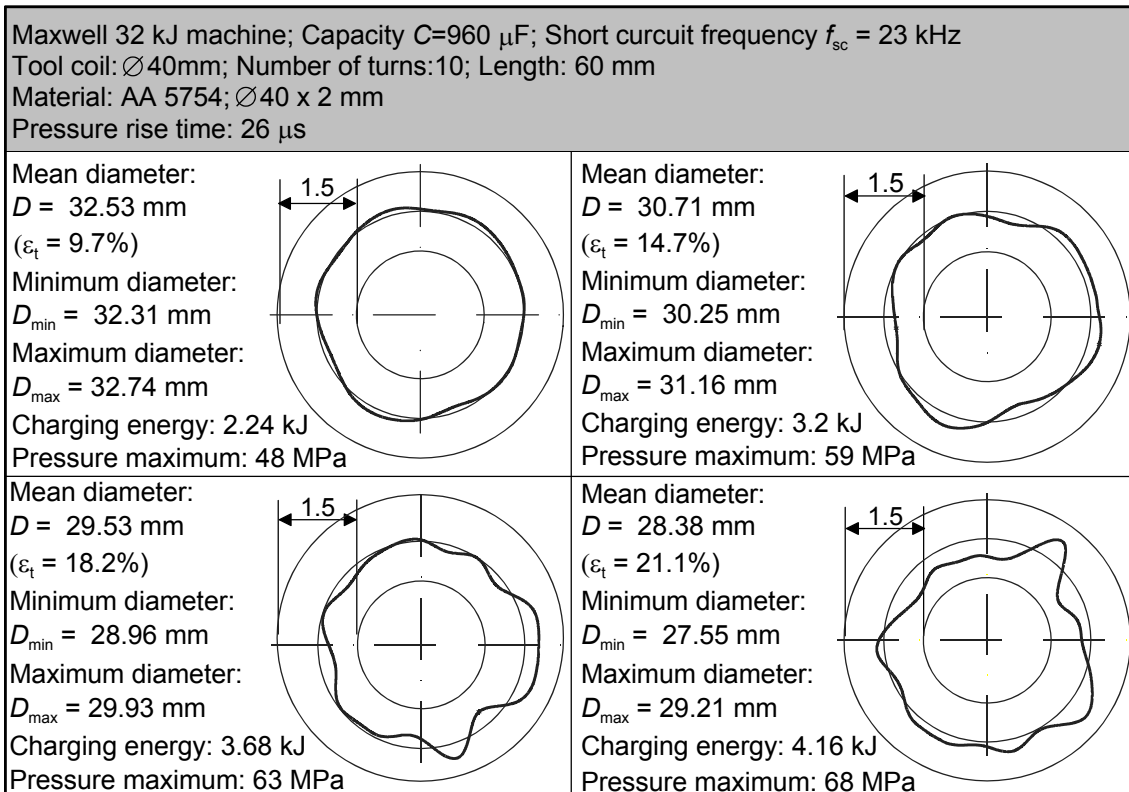

Figure 2: Roundness plots of specimen of different tangential strain

For the valuation of the achieved roundness it has to be taken into account that the compression process is a preforming operation and that the calibration shall be realised by the subsequent hydroforming step. It is not necessary to achieve the geometric tolerances requested for the final part, but up to a certain limit geometric deflections can be corrected and wrinkles are reversible.

3.2 Correlation between Tangential Strain and Strain Hardening Effect

In addition to the described influence on the roundness of the preform, the tangential strain also influences the material properties which can be characterised by the hardness. To analyse this influence, Vickers hardness tests have been performed on specimen with different tangential strain. Figure 3 shows the results of selected experiments.

As it is known from quasistatic forming operations, the hardness in this high speed compression process also increases with a rising tangential strain due to the strain hardening effect. Furthermore, the increase of hardness seems to be stronger for small deformations and to decline slightly for further strain.

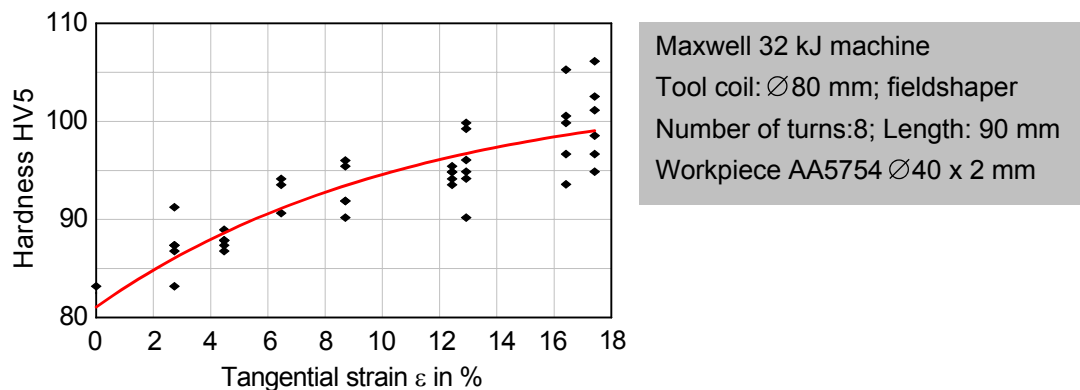

Figure 3: Vickers hardness of tubular specimen with different tangential strain

The strain hardening, resulting from the electromagnetic preforming operation, is of particular importance for the subsequent hydroforming step, because the remaining forming capability in the preformed workpiece areas will be reduced due to an increasing reduction of the tube diameter. Furthermore, the needed pressure during the hydraulic expansion is higher for harder materials.

To quantify these effects, hydraulic burst tests are necessary. Since there is no distinct correlation known between the maximum tangential strain and the maximum uniaxial strain determined in tensile tests, the burst test is essential to estimate the formability in case of tube hydroforming conditions. Although the forming capability of the material decreases according to the increasing hardness (compare Figure 3), it is not completely depleted after the electromagnetic compression up to a tangential strain of about 18%.

4 Influence of the Forming Velocity

4.1 Influence of the Pressure Rise Time on the Strain Rate

The frequency of the pressure course, and therefore also the pressure rise time, directly refers to the frequency of the coil current which is determined by the elements of the oscillating circuit, especially the inductance and the capacity. This means that the pressure course can be adjusted by the adaptation of tool coil and forming machine [7].

With the aim of analysing the influence of the pressure rise time on a tube deformation process, experiments have been performed with several tool coils and two different forming machines available at the Chair of Forming Technology of the University of Dortmund. Figure 4 presents two examples of different pressure over time curves leading to the same final workpiece deformation. The according compression of the tubes is quantified as the course of the radial displacement of the smallest cross section. For the comparison of these curves it is helpful to use the derivation which corresponds to the tangential strain rate. Therefore, the strain rate over strain functions, which are the referring values for velocity and displacement, can also be seen in Figure 4.

The comparison of the pressure course and the according displacement course shows that after the beginning of the pressure rise there is a short delay before the workpiece deformation starts. This retardation is caused by inertia effects which have to be exceeded by the applied pressure. Furthermore, it can be seen that the plastic deformation of the workpiece is completed during the first half wave of the magnetic pressure. This

behaviour has been observed in every compression process of aluminium tubes, because here, in contrast to the electromagnetic expansion and sheet metal forming, the stiffness of the workpiece increases due to the forming operation.

From the comparison of the two processes shown in the diagrams it can be concluded that in order to achieve a defined radial deformation with a shorter pressure rise time, the maximum pressure has to be higher. Additionally, it is obvious that a faster rise of the pressure also leads to a higher strain rate.

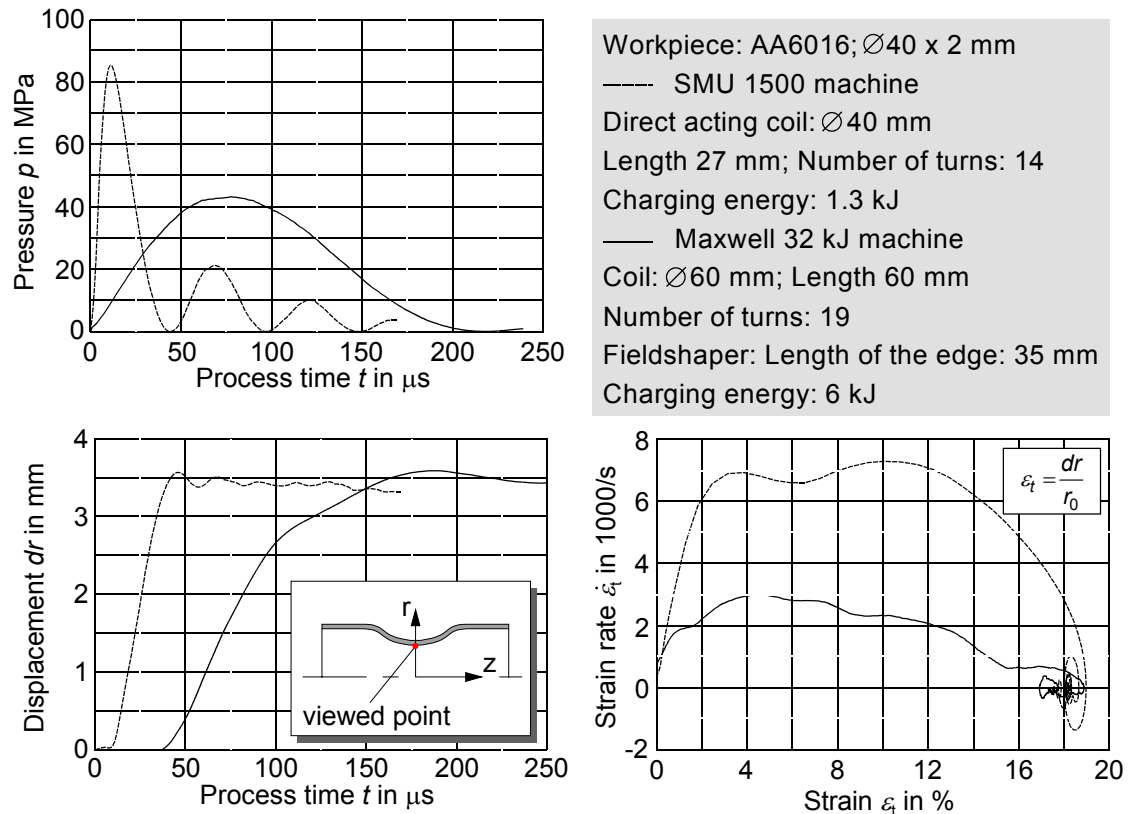

Figure 4: Different pressure impulses and according workpiece deformations

4.2 Influence of Pressure Rise Time on Roundness

For further investigations regarding the influence of the pressure rise time on the roundness of the resulting preform, additional experiments have been performed. To except the influence of the tool coil parameters, especially the length, several experiments have been performed using one and the same tool coil. The variation of the pressure course has been realised by using an EMF-machine, provided by the company Poynting GmbH, Dortmund. This machine offers a maximum charging energy of 60 kJ. Depending on the charging energy needed it is possible on this machine to use capacitor banks of different sizes separately or in any user-defined combination in order to optimise the pressure course for a special forming task. Different specimen with nearly the same tangential strain have been produced with this machine. Exemplary results are shown as roundness plots in Figure 5.

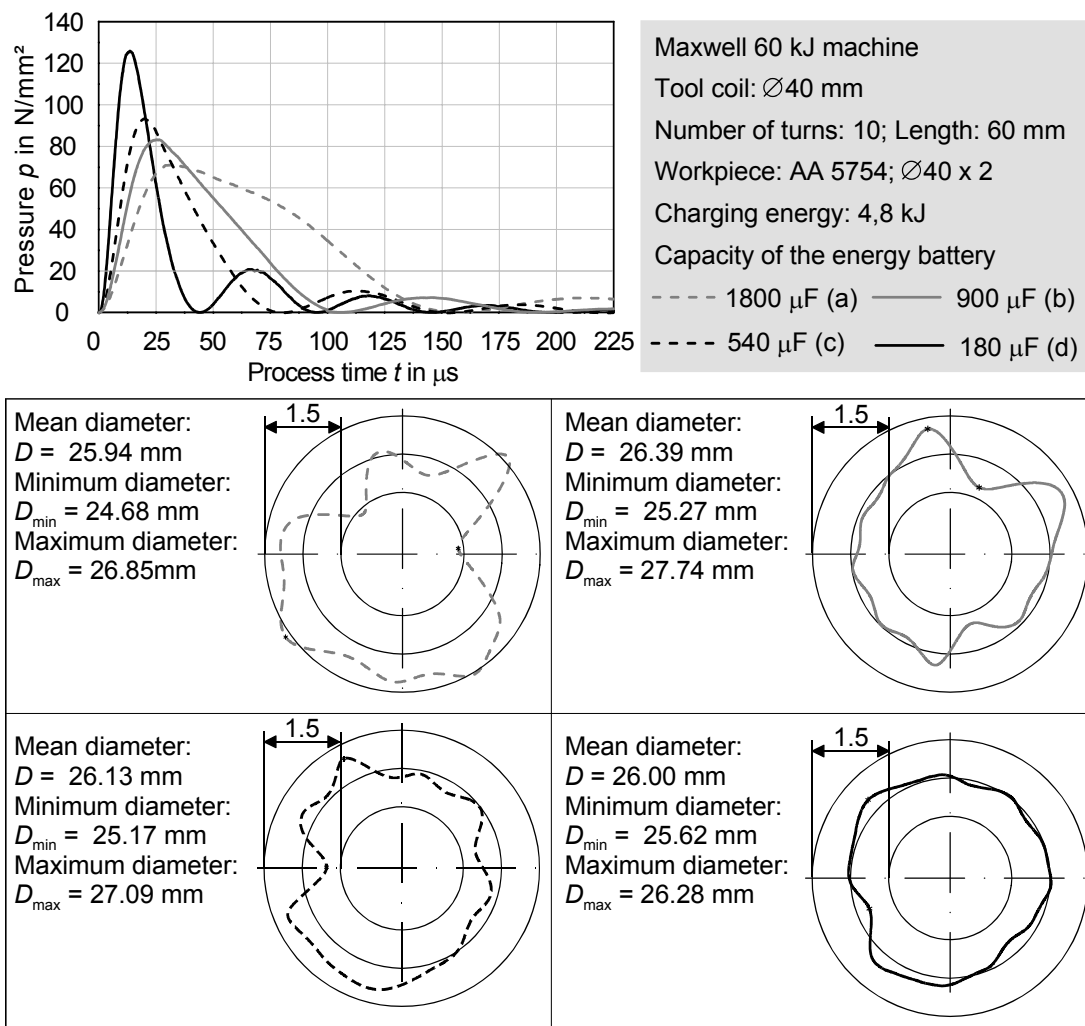

Figure 5: Influence of the strain rate on the roundness

As it can be seen from this Figure, the mean diameter of the compressed tubes is similar. It varies between 25,94 mm and 26,39 mm. The deformations have been achieved using nearly the same charging energy of the capacitors.

Furthermore, a trend of an improved roundness due to a shorter pressure rise time and the according higher strain rate can be seen. This shows that a faster process reacts less sensitive to inhomogeneities, like e.g. extrusion seams or differences in the wall thickness. Localising effects seem to be reduced for higher forming velocities. The comparison of quasistatic and highspeed tube compression processes is an extreme example confirming this result. As already mentioned, a free compression is, in general, not possible by means of hydroforming. In contrast to this, a free electromagnetic compression process shows in many cases good results.

4.3 Influence of Pressure Rise Time on Strain Hardening

In addition to the influence of the pressure rise time on the resulting roundness of the preform, a possible dependence of the strain hardening on the pressure rise time has been investigated as well. To clarify, whether the forming velocity has an influence, results of

Vickers hardness tests performed on tubes, compressed with different strain rates, have been compared. Figure 6 shows the resulting hardness of the specimen according to the roundness plots presented in Figure 5, whereby the different strain rates are labelled as a, b, c, and d (with $a < b < c < d$). The measured hardness here is very similar for all specimen and no clear trend due to an increasing strain rate can be recognised. Therefore, it can be concluded that within the range of the regarded velocities the strain hardening only depends on the tangential strain and not on the strain rate.

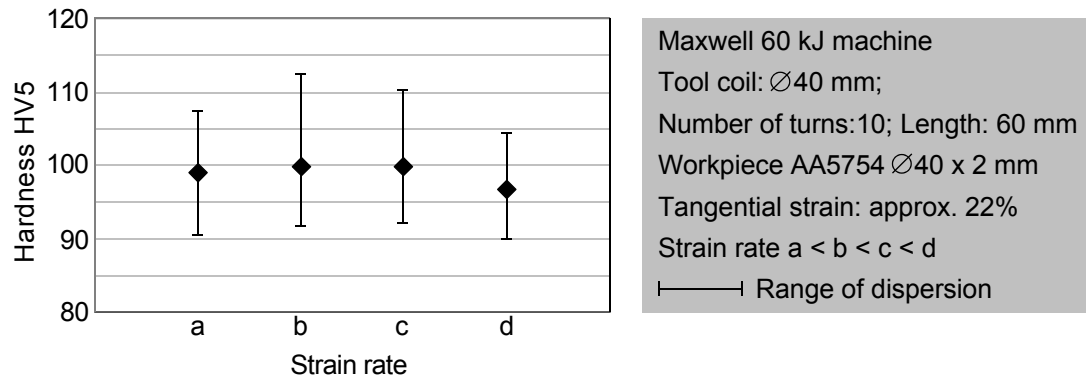

Figure 6: Influence of the strain rate on the strain hardening

This perception has been approved by the comparison of quasistatic and high speed forming processes. For this purpose Vickers hardness tests have been performed on electromagnetically and hydraulically expanded tubes. This approach assumes that the direction of the deformation does not influence the resulting hardness. This means that for the same tangential strain, compression and expansion will lead to the same hardness.

The tests have shown that, for example, a tangential strain of approx. 7.5% leads to a hardness of approx. HV5 = 92 in case of the hydraulically expanded tube, and to a hardness of approx. HV5 = 94 in case of the electromagnetically expanded tubes. A comparison with the results shown in Figure 3 approves the assumption that the hardness does not depend on the direction of the radial deformation.

5 Conclusions and Outlook

The investigations and results presented in this paper concentrate on the free electromagnetic compression process used as a preforming operation for hydroforming workpieces. An important precondition for this approach is that the remaining forming capability is high enough, so that occurring geometric deflections can be reversed and the final workpiece geometry can be realised by the subsequent hydroforming step.

It has been shown that a higher tangential strain, achieved by a higher pressure impulse, is correlated to an increasing wrinkling effect as well as to an increasing strain hardening effect. Furthermore, it has been found out that for a defined tangential strain a higher strain rate, caused by a shorter pressure rise time, leads to a better roundness, while the strain hardening remains unaffected. Comparing burst tests of tubes in the initial condition and on electromagnetically preformed tubes indicate that the forming capability is not depleted after the electromagnetic compression.

The consequent continuation of the presented research work is the investigation of the form defined electromagnetic compression. This allows an extension of the range of applications and makes it possible to produce geometries which typically occur in hydroforming parts for the automotive industry. Complicated forms including asymmetric cross section geometries as well as shifted ones [8] shall already be realised in the preforming step by means of electromagnetic forming. In this case, the preformed areas of the workpiece should have a shape which is as close as possible to the finished part geometry. The further investigation of this approach strongly depends on the desired workpiece geometry and will be performed within the above mentioned EU- project, exemplary by the production of a demonstrator.

References

- [1] *Birkert, A.*: Herstellung von Strukturbauteilen durch Innenhochdruck-Umformen, Diss., Institute for Metal Forming Technology, University of Stuttgart, 2000.
- [2] *Heizmann, J.*: Activator Assisted Forming Technologies – Status and Outlook, Proceedings of the International Conference on Hydroforming, Fellbach, 2003, p. 1- 6.
- [3] *Dohmann, F.; Lange, K. (publisher)*: Innenhochdruckumformen, Umformtechnik - Handbuch für Industrie und Wissenschaft, Volume 4, Springer-Verlag, Berlin/ Heidelberg, 1993.
- [4] *Schroeder, M.*: Recent Developments in the Hydroforming of Tubular and Sheet Blanks – Semi Productive and Productive, Proceedings of the International Conference on Hydroforming, Volume 3, Fellbach, 2003, p. 165- 184.
- [5] *Beerwald, C.; Brosius, A.; Homberg, W.; Kleiner, M.; Wellendorf, A.*: New aspects of electromagnetic forming, Proceedings of 6th International Conference on Technology of Plasticity, Nürnberg, 1999, p. 2471- 2476.
- [6] *Beerwald, C.; Brosius, A.; Kleiner, M.*: Determination of flow stress at very high strain-rates by a combination of magnetic forming and FEM calculation, Proceedings of the International (CIRP) Workshop on Friction and Flow Stress in Cutting and Forming, Paris, 2000, p. 175- 182.
- [7] *A. Henselek, M. Beerwald, C. Beerwald*: Design and Adaption of EMF Equipment - From Direct Acting Multi-turn Coils to Separable Tool Coils for Electromagnetic Tube Compression, Proceedings of the International Conference on High Speed Forming, Dortmund, 2004.
- [8] Verein Deutscher Ingenieure (publisher): VDI- Richtlinie 3146, Hydroforming – Basic knowledge, VDI- Verlag, Düsseldorf, 1999.