

Modular Polymer Electrolyte Membrane Fuel Cell and Electrolyser Stack Design with Hydraulic Compression

Ulrich Rost, Jeffrey Roth, Michael Brodmann

Westphalian Energy Institute of the Westphalian University of Applied Science
Gelsenkirchen, Germany
ulrich.rost@w-hs.de

Abstract—An energy economy with high share of renewable but volatile energy sources is dependent on storage strategies in order to ensure sufficient energy delivery in periods of e.g. low wind and/or low solar radiation. Hydrogen as environmental friendly energy carrier is thought to be an appropriate solution for large scale energy storage. In 2011 the NOW (national organisation for hydrogen in Germany) calculated the demand for hydrogen energy systems as positive (0.8 GW to 5.25 GW) and negative supply for varying power demand (0.68 to 4.3 GW) for the German energy economy in 2025 [1]. Due to its dynamic behaviour on load changes polymer electrolyte membrane fuel cells (PEMFC) as well as water electrolyser systems (PEMEL) can play a significant role for large scale hydrogen based storage systems. In this work a novel design concept for modular fuel cell and electrolyser stacks is presented with single cells in pockets surrounded by a hydraulic medium. This hydraulic medium introduces necessary compression forces on the membrane electrode assembly (MEA) of each cell within a stack. Furthermore, ideal stack cooling is achieved by this medium. Due to its modularity and scalability the modular stack design with hydraulic compression meets the requirements for large PEMFC as well as PEMEL units. Small scale prototypes presented in this work illustrate the potential of this design concept.

Keywords—PEMFC, PEMEL, modular stack design, hydraulic compression

I. INTRODUCTION

In the year 2050 Germany intends to generate over 80% of its electrical energy by renewable sources [2]. To succeed in transforming the German energy sector towards this high share of renewable energy sources huge effort has to be made in improving electrical grid infrastructure as well as in extending energy storage. To fulfil carbon dioxide emission targets it is common sense to result in carbon free strategies.

Producing hydrogen (H_2) and oxygen (O_2) in water electrolyzers is a potential solution for using excess energy in periods of low demand [3]. Storing large amounts of H_2 in caverns under earth and transportation of it in pipelines is shown at few locations worldwide [4]. In order to generate electrical energy in times of high demand fuel cell systems can be powered by H_2 and O_2 or air. Due to high power density and dynamic part load operation polymer electrolyte membrane

(PEM) based fuel cell or electrolyser systems are appropriate for this purpose [5 – 6]. Demonstration projects in Germany, like ‘ H_2 Herten’ or ‘Falkenhagen’, started operation within the last months [7 – 8].

The main component in PEMFCs as well as PEMELs is the membrane electrode assembly (MEA). MEAs for PEMFCs (Figure 1) consist of an ions conducting but electrical insulating membrane, which is coated from both sides with catalytic material (CCM – catalyst coated membrane) and, furthermore, an electrical conducting gas diffusion layer (GDL) on the anode as well as on the cathode side. Such a MEA is placed between two pole plates with gas channels (flow field). Together these components form a single fuel cell. In operation H_2 and O_2 or air (ca. 21 % O_2) are supplied over the flow field and finely distributed to the catalyst due to the high porosity of a GDL. H_2 is delivered to the anode and O_2 is delivered to the cathode, where product water evolves ($H_2 + \frac{1}{2} O_2 \rightarrow H_2O + \Delta H$ with ΔH equals 3 kWh m^{-3} according to the lower heating value (LHV) of H_2) [9 – 12]. PEMEL working the other way round ($H_2O + \Delta H \rightarrow H_2 + \frac{1}{2} O_2$ with ΔH equals 3.6 kWh m^{-3} according to the higher heating value (HHV) of H_2) are designed in a very similar way, therefore, description in more detail is negligible for this work.

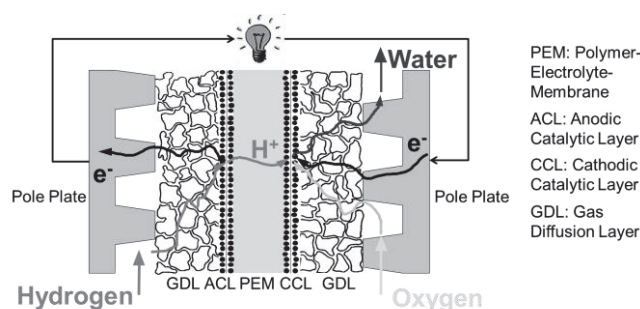

Figure 1: Schematic drawing of a PEMFC cross section

Conventional fuel cell stacks consist of several single fuel cells connected electrically in series which increases stack voltage at constant current. To reduce electrical resistance pole plates are constructed in bipolar design, so that a flow field is arranged on each side of the plates. Mono-polar plates are placed on the stacks extremities with a flow field only on one

side. Furthermore, special pole plates which have channels for cooling water can be placed within the stack to protect it from overheating. Over two strong endplates which are pulled together by tie bolts, necessary compression forces are induced (see Figure 2) [9, 11, 12].

To reduce reactance within PEMFC or PEMEL stacks (describing gas flow losses as well as electrical losses) without setting down porosity of the electrode's layers, an optimal compression over the whole cell surface is needed. Therefore, homogenous cell compression is a central requirement for PEMFC as well as PEMEL systems [13 – 20]. Since, temperature conditions of an electrochemical cell have tremendous impact on the operation characteristics it has to be taken into account of [11, 12, 21].

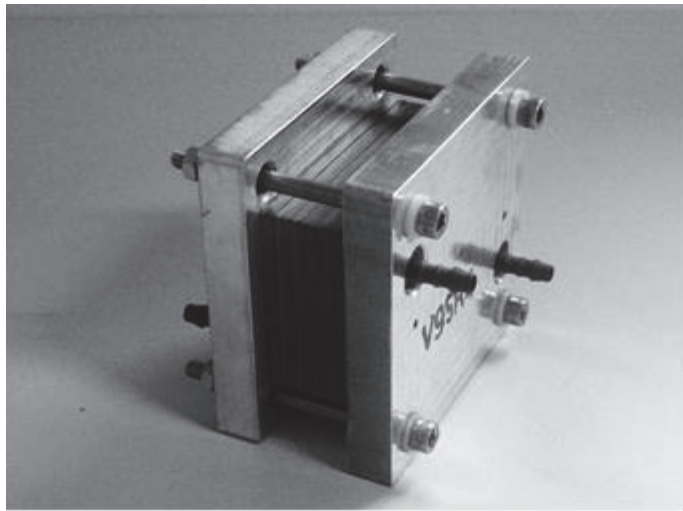

Figure 2: Photograph of a PEMFC with mechanical compression over tie bolts

II. MODULAR STACK DESIGN WITH HYDRAULIC COMPRESSION

A. Fuel Cell Stack Design

At the Westphalian University of Applied Sciences in Gelsenkirchen a new stack design for electrochemical cells based on hydraulic compression of single cells has been patented [22]. With this stack design fuel cell systems can be constructed which contain a variable defined number of single cells which are connected in series over flexible copper ribbon cables. These are arranged in flexible pockets within a pressure tank filled up with fluid. In operation cells are fixed within the tank by pressurising this fluid. However, e.g. for maintenance reasons pressure can be released so that changing cells is possible. CAD design is shown in Figure 3. A detailed explanation of a modular fuel cell stack with exchangeable spare parts is given in [23, 24].

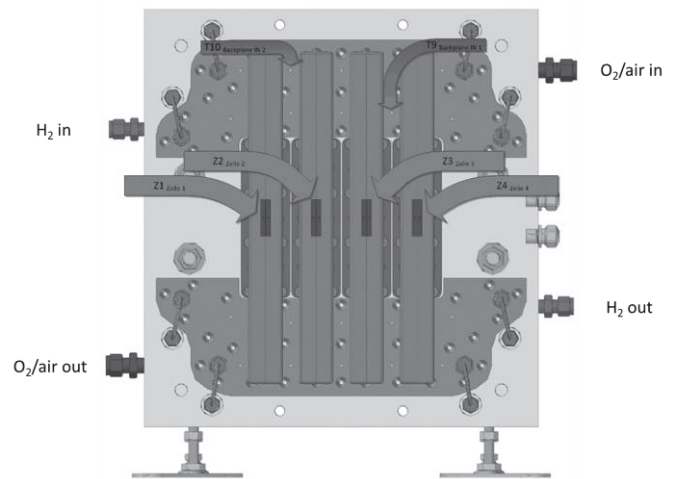

Figure 3: Schematic drawing of a modular PEMFC with four single cells (view from on top)

During operation a hydraulic medium surrounds each fuel cell of the presented stacks in the way that surface pressure on each cell is identical. The hydraulic pressure within the stack is controlled by a pneumatic actuator. The system's pressure control keeps a constant pressure level. This is necessary at e.g. start-up procedure, when stack temperature rises from room temperature to operating temperature (ca. 60 °C – 80 °C). Furthermore, temperature of the whole stack can be controlled by cooling the hydraulic medium. This guarantees homogeneous temperature distribution for each cell as well as protection against overheating. Waste heat recuperation for a combined heat and power system (CHP) can easily be realised. Hence, operation conditions with this type of stack are nearly ideal, if the parameters of the delivered process gases are constant. In order to deliver gases with identical physical characteristics to each fuel cell, these are connected in parallel to temperature controlled manifolds (for O₂/air as well as for H₂). Each cell has a clip which connects it to this manifold. However, connecting cells gas technically in series is also possible with another kind of manifold which joins a cell's outlet with the next cell's intake. But due to unfavourable pressure drop after each cell, delivering the gases in series is limited to only few cells.

Two fuel cell stack prototypes with hydraulic compression have been realised so far. Water has been used for cell compression as temperature limit for PEMFC is ca. 80 °C. However, high temperature PEMFC systems (up to 200 °C) can be realised by using thermal stable oil instead. The first prototype A is constructed with three fuel cells with an active cell area of 20.25 cm² (45 mm x 45 mm) and a four channels flow field. Photograph of this small scale module is shown in Figure 4.

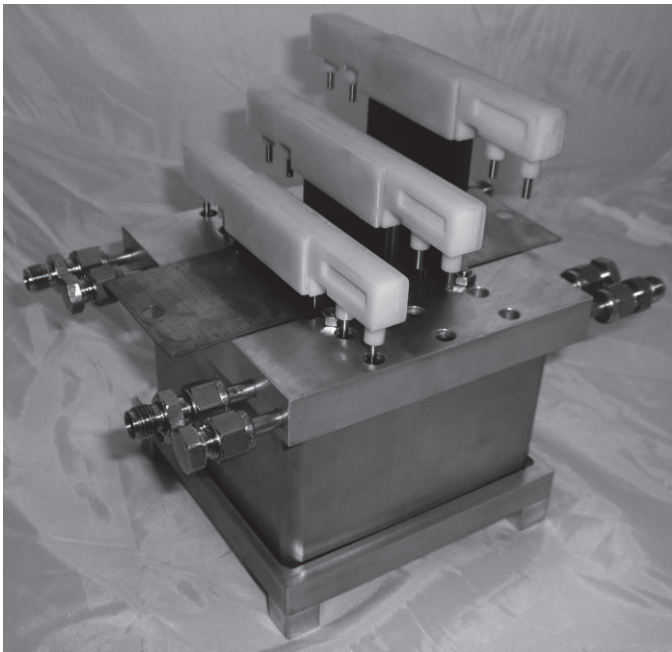

Figure 4: Photograph of a PEMFC with hydraulic compression

The second prototype B is a stack with four cells. Each cell has an active cell area of 182.35 cm^2 ($93 \text{ mm} \times 197 \text{ mm}$). Flow field design is different due to rectangle design. Furthermore, flow field is realised by 13 parallel channels.

B. Electrolyser Stack Design

Due to electrochemical pressurisation with PEMEL H_2 and O_2 can be produced at a high pressure level e.g. above 50 bar. This is interesting for power-to-gas systems which feed produced H_2 directly into a gas pipeline without further mechanical pressurisation. Diverted from the modular stack design with hydraulic compression a new concept for a high pressure electrolyser has been applied for patent [25]. Here a modular PEMEL with hydraulic compression is capsuled within an outer pressure container. The pressure in the outer capsule is controlled according to the inner electrolyser cell pressure. This concept overcomes sealing problems as differential pressure between inner cell and outer capsule is controlled to a level of maximum 5 bar. Furthermore, the hydraulic medium for cell compression can also be controlled according to the inner cell pressure. This is favourable as the MEA of each cell can be compressed at an optimum compression level over the whole range of delivery pressure.

A prototype for a modular high pressure PEMEL with hydraulic compression is recently under development. After consideration of basic design elements like the pole plate design, within the scope of an ongoing project a 60 kW electrolyser system with 72 cells each producing at least $0.1 \text{ Nm}^3 \text{ h}^{-1}$ is developed. First design study of this electrolyser with 250 cm^2 active cell area can be seen in Figure 5. A low cost design is expected by the use of low cost components for this system. In order to achieve necessary knowledge a small scale prototype has been constructed first with an active cell area of 25 cm^2 ($50 \text{ mm} \times 50 \text{ mm}$).

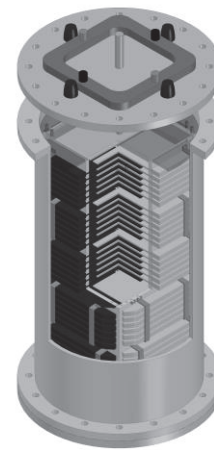

Figure 5: CAD drawing of a 60 kW high pressure PEMEL with hydraulic compression

III. EXPERIMENTALS, RESULTS AND DISCUSSION

MEAs for the fuel cell prototypes as well as for the electrolyser prototype have been prepared by commercially available components. All stacks have been characterised according to their polarisation behaviour in full automated test benches with process media treatment and monitoring. The fuel cell test bench is connected to a central H_2 gas storage. Ambient air is delivered to the cathode by a diaphragm pump. For safety reasons nitrogen can be purged through the gas channels e.g. in order to remove oxygen in the anodic gas path. Mass flow, temperature and pressure of the feed gases are detected. The electrolyser test bench is equipped with feed water heating. Temperature and pressure of the feed water as well as of the excess gases are monitored. All measurements are saved in a central data base. Both test benches are connected to the safety infrastructure of the laboratory for a safe unattended operation.

Polarisation curves for the described fuel cell stacks have been determined with an electronically controlled load type Höcherl & Hackl ZS1806NV (maximum load current is 150 A). DC power supply type Deutronic D-IPS 40A/30V has been used for water electrolysis. Polarisation curves are determined at constant current mode. Corresponding voltage is measured.

A. Characterisation of Fuel Cell Stacks

For both prototypes pole plates are manufactured from graphite due to its high electrical and thermal conductivity. MEAs have been prepared from Gore® components. As CCM Primea® FCM has been used. Carbel® GDM CNW20B has been taken as GDL. Cell assembly is handmade.

Both stacks are investigated in H_2 /air operation at room temperature. Stacks have start-up condition. MEAs are conditioned by fast cycling procedure according to the Gore® data sheet. H_2 with high purity 6.0 is delivered with slightly overpressure of 0.2 bar. Hydrogen is circulated by a diaphragm pump from the anodic outlet to the anodic intake in order to save fuel. Only the amount of consumed H_2 is fed to the anodic gas path. Ambient air and hydrogen are delivered without additional humidification. Air stoichiometry is set to $\lambda = 3.5$ which means 3.5 times more oxygen is delivered to the

fuel cell as would be needed for an entire reaction. The λ -control is implemented in the test bench's PLC (programmable logic controller).

Figure 6 shows polarisation curve of prototype A with each cell having an active cell area of 20.25 cm². Polarisation curve of prototype B with each cell having an active cell area of 182.35 cm² can be taken from Figure 7.

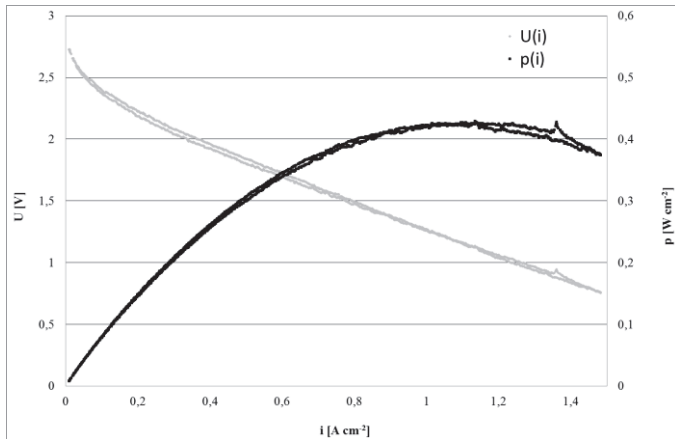

Figure 6: Polarisation curve of modular PEMFC stack with three cells

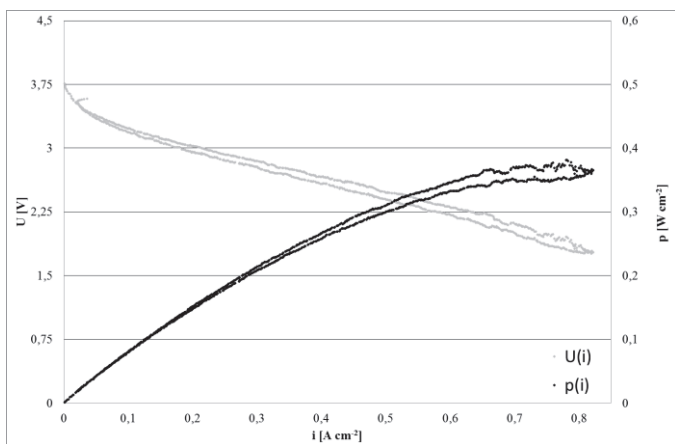

Figure 7: Polarisation curve of a modular PEMFC stack with four cells

Open circuit voltage of both fuel cell prototypes is in the range of 0.9 V for each cell (theoretical maximum is 1.2 V according to LHV). For prototype A 2.7 V and, respectively, for prototype B 3.7 V has been measured in open circuit. This effect occurs due to activation losses referred to the electrochemical reactions. At fuel cell operation voltage drops nearly linearly with the applied load up to the point of maximum power output. This results from the internal resistance as well as from ionic membrane losses.

For nearly ambient conditions (stack temperature at 30 °C, operation with un-humidified ambient air) maximum power output of fuel cell prototype A is in the range of 27 W (0.43 W cm⁻²) at an output voltage of 1.15 V ($\eta = 32\%$). Maximum power output of fuel cell prototype B is 290 W (0.38 W cm⁻²) at an output voltage of 1.92 V ($\eta = 39\%$). Although active cell area is different by a factor of nine specific maximum power

output is in the same range. As linear upscaling of a pole plate design is not possible in most cases, slightly design differences are necessary (e.g. channel length, channel diameter or channel number). Therefore, differences in power output of prototype A and B occur mainly due to different flow field design. Furthermore, increase of resistance losses is likely due to higher current of prototype B. However, increasing diameter of the connecting copper cables can be an appropriate solution.

Long term operation of prototype A and B results in stack temperature of above 50 °C. At higher temperatures reaction kinetics is increased. Therefore, higher power output would be expected. But problems occurred due to un-humidified operation which decreases ionic conductivity of the PEM. This results in un-stable operation. Recuperation of excess humidity could be an appropriate solution. However, for small scale PEMFC stacks (< 1 kW) recuperation systems are not commercially available.

B. Characterisation of Electrolyser Stack

The electrolyser pole plates are manufactured from thin titanium sheets. Instead of a flow field a simple pocket is formed into the material. Titanium felt is used for distribution of water to the catalyst layer. This felt fits into a pole plate's pocket. MEAs for the electrolyser prototype are prepared by fumea® as CCM and titanium felt, both from Fumatech®.

Water is circulated on the anode as well as on the cathode side in order to achieve nearly identical pressure level. Feed water is tempered to constant conditions up to 50°C. Polarisation curves shown in Figure 8 have been determined for 30, 40 and 50 °C.

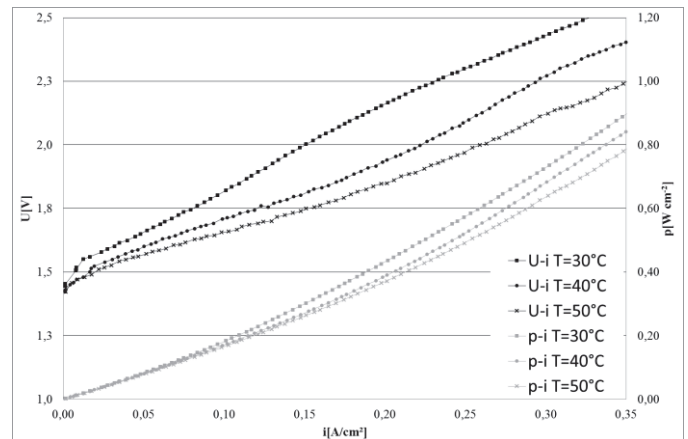

Figure 8: Polarisation curve of a modular PEMEL stack with one cell

The electrolyser prototype presented in this work shows power consumption of 13.25 W (0.53 W cm⁻²) at a cell voltage of 2 V. Respectively, this refers to hydrogen evolution of about 2.7 Ndm³ h⁻¹. The specific energy demand is 4.9 kWh Nm⁻³H₂. Increasing the DC power would lead to further H₂ production. However, due to higher cell voltage this results in increased electrode corrosion phenomena. Especially carbon content within the CCM is prone to electro corrosion. Dissolution of parts of the electrode results in decrease of catalytic material. Therefore, for long term operation cell voltage of below 2 V is suggested.

Like for PEMFC operation at higher temperatures results in better PEMEL performance due to increased reaction kinetics. Power consumption for the production of $2.7 \text{ Nm}^3 \text{ h}^{-1}$ is reduced from 15.25 W at $30 \text{ }^\circ\text{C}$ to 13.25 W at $50 \text{ }^\circ\text{C}$ (decrease of 14 %). For large scale units PEMEL stack cooling controls temperature to $80 \text{ }^\circ\text{C}$. Therefore, further improvements are expected for the large scale prototype (72 cells, 60 kW).

In comparison to state of the art PEMEL systems¹ power density is rather low for the presented prototype, but specific energy demand indicates high stack efficiency ($> 70 \%$ according to HHV of H_2). However, stack and cells are manufactured with a focus on the ability of series production in order to achieve costs targets for the large scale prototype. Stainless steel pressure containers used for this application have standard dimensions. Pole plate forming is achieved by mechanical pressing which is known for mass production. Titanium felts as well as the CCMs can be produced in large scale. Further cost reductions can be achieved e.g. by the use of titanium meshes, but further investigations would be needed.

IV. CONCLUSIONS

Upscaling the presented 20.25 cm^2 cell geometry to factor of nine decreases specific power output of 12 %. For prospective applications it is expected to realise single cells with very large active cell area above $1,000 \text{ cm}^2$ having specific power output of at least 0.35 W cm^{-2} in robust operation mode (ambient conditions, H_2/air , no humidification). Increasing number of cells does not affect specific power output significantly. Therefore, it can be concluded that realising large scale stacks with any number of cells is possible. This may attract PEMFC based stationary applications, especially, for high temperature PEMFC.

In order to result in a 60 kW high pressure PEMEL stack, upscaling the presented small scale prototype is necessary. From obtained results on PEMFC stacks it can be concluded that upscaling is possible. The presented stack design already shows a construction route for low cost systems which is necessary for large scale applications.

Few design changes are needed to convert the presented stacks into energy systems with waste heat recuperation. E.g. a CHP system for household heating can operate by heat exchanging a PEMFC stack's inherent cooling water which is also used for cell compression. For large scale hydrogen energy systems based on the presented design concept industrial CHP is imaginable.

REFERENCES

- [1] T. Smolinka, M. Günther, J. Garcke (2011): Stand und Entwicklungspotenzial der Wasserelektrolyse zur Herstellung von Wasserstoff aus regenerativen Energien. Available at: http://www.hs-ansbach.de/upload/tx_nxlinks/NOW-Studie-Wasserelektrolyse-2011.pdf. Accessed: 2014-11-11
- [2] Bundesministerium für Wirtschaft und Technologie und Bundesministerium für Umwelt, Naturschutz und Reaktorsicherheit (2010): *Energiekonzept*. Available at: http://www.bundesregierung.de/ContentArchiv/DE/Archiv17/_Anlagen/2012/02/energiekonzept-final.pdf?__blob=publicationFile&v=5. Accessed: 2014-11-11
- [3] D. Stolten (Ed): Hydrogen and Fuel Cells. Wiley-VCHWeinheim, 2010, pp. 207-226.
- [4] D. Stolten (Ed): Hydrogen and Fuel Cells. Wiley-VCHWeinheim, 2010, pp. 121-148.
- [5] Ballard, press release (2010): Ballard Tests 1 MW PEM Power Plant. Available at: <http://www.h2euro.org/2010/ballard-tests-1-mw-pem-power-plant>. Accessed: 2014-11-11
- [6] D. Stolten (Ed): Hydrogen and Fuel Cells. Wiley-VCHWeinheim, 2010, pp. 755-786.
- [7] K. Klug (2013): Wasserstoff als Energiespeicher. Available at: http://www.brennstoffzelle-nrw.de/fileadmin/daten/jahrestreffen/2013/11_Klug_WF-HS-GE_Windstrom-Herten_NBW20131114.pdf. Accessed: 2014-11-11
- [8] E.ON, press release (2013): E.ON nimmt „Power to Gas“-Pilotanlage im brandenburgischen Falkenhagen in Betrieb. Available at: <http://www.eon.com/de/presse/pressemitteilungen/pressemitteilungen/2013/8/28/eon-nimmt-power-to-gas-pilotanlage-im-brandenburgischen-falkenhagen-in-betrieb.html>. Accessed: 2014-11-11
- [9] J. Zhang (Ed): PEM Fuel Cell Electrocatalysts and Catalyst Layers Fundamentals and Applications. Springer Verlag, London, 2008, pp. 1-88.
- [10] A. Heinzl, F. Mahlendorf, J. Roes: Brennstoffzellen Entwicklung, Technologie, Anwendung, third ed., C.F. Müller Verlag, Heidelberg, 2006.
- [11] C. Hamann, W. Vielstich, Elektrochemie, third ed., Wiley-VCH, Weinheim, 1998.
- [12] F. Babir, PEM Fuel Cells Theory and Practice, second ed., Elsevier, Waltham, San Diego, London, 2013.
- [13] P. Zhou, P. Lin, C.W. Wu, Z. Li, International Journal of Hydrogen Energy 36 (2011) 6039-6044.
- [14] S. Asghari, M.H. Shahsamedi, M.R. Ashraf Khorasani, International Journal of Hydrogen Energy 35 (2010) 9291-9297.
- [15] S. Asghari, A. Mokmeli, M. Samavati, International Journal of Hydrogen Energy 35 (2010) 9238-9290.
- [16] P.A. Garcia-Salaberri, M. Vera, R. Zaera, International Journal of Hydrogen Energy 36 (2011) 11856-11870.
- [17] S. Park et al., International Journal of Hydrogen Energy 38 (2013) 6481-6493.
- [18] D. Qiu, P. Yi, L. Peng, X. Lai, International Journal of Hydrogen Energy 38 (2013) 6762-6772.
- [19] X. Wang, Y. Song, B. Zhang, Journal of Power Sources 179 (2008) 305-309.
- [20] X.Q. Xing, K.W. Lum, H.J. Poh, Y.L. Wu, Journal of Power Sources 195 (2010) 62-68.
- [21] J.G. Pharoaha, O.S. Burheimb, Journal of Power Sources 195 (2010) 5235-5245.
- [22] M. Brodmann, M. Greda, J. Roth, C. Mutascu, DE102009057494 A1 (German patent)
- [23] M. Brodmann, M. Greda, Hzwei 04/12 (2012) 14-15.
- [24] U. Rost, M. Brodmann, V.-A. Şerban, C. Mutascu, J. Roth, B. Zekorn., Scientific Bulletin of the “Politehnica” University of Timisoara, Romania Transactions on Mechanics, Vol. 57 (71), Iss. 2 (2012) pp. 1-6
- [25] M. Brodmann, U. Rost M. Greda, J. Roth, C. Mutascu, A. Wildometz, DE102012018243 A1 (German patent)

¹ $0.6 - 4.4 \text{ W cm}^{-2}$ at $80 \text{ }^\circ\text{C}$; $4.5 - 7.5 \text{ kWh m}^{-3} \text{ H}_2$ [1]